

Driver LCO 110W 200–1050mA 157V pD+ NF C SNC

essence D4i NFC outdoor series

**Product description**

- _ Dimmable IP20 built-in constant current driver. DALI-2 and D4i certified.
- _ Setting the industry standard: high surge immunity, NFC programming, long life-time, high Power Factor and efficiency
- _ Dual integrated power supply for the ZD4i ecosystem (bus power supply and 24 V DC AUX power supply to power sensors and controls)
- _ Integrated power monitoring and energy reporting
- _ For standalone luminaires to achieve adaptive lighting requirements or streetlights that are interconnected with smart lighting systems
- _ For luminaires of protection class I and II and additional equipotential for more design-in flexibility
- _ Fully programmable via NFC (wireless) or DALI. Selected features can be programmed via cabinet programming (u6Me2).
- _ Nominal lifetime up to 100,000 h
- _ 5 years guarantee + 3 years of warranty extension depending on operating conditions (conditions at <https://www.tridonic.com/en/int/services/manufacturer-guarantee-conditions>)

Interfaces

- _ Near field communication (NFC) for programming and configuration (single and multi packaging)
- _ DALI-2 and D4i (powered DALI-2)
- _ u6Me2 cabinet programming for the configuration of chronoSTEP times and levels via mains
- _ Terminal blocks: 45° push terminals

Functions

- _ Integrated bus power supply for sensors and other control devices (DALI part 250)
- _ Integrated auxiliary power supply 24 V, 3 W (DALI part 150) for control devices with higher power requirements
- _ Data specification (DALI part 251, 252 and 253 for report of luminaire, energy and diagnostics data)
- _ Autonomous dimming function "chronoSTEP": programmable via NFC, DALI, u6Me2
- _ Constant light output function (CLO)
- _ Full protection set (overtemperature, short-circuit, overload, no-load, undervoltage / overvoltage, reduced surge amplification)
- _ deviceKEY against unauthorized change of parameters

Benefits

- _ Future proof driver with chronoSTEP, DALI-2 and D4i dimming capability combined in one device
- _ Robust thermal behaviour to ease design-in
- _ Sensors and communication devices are directly powered from the driver and are therefore easy to integrate into the luminaire
- _ Flexible driver configuration via companionSUITE software (NFC, DALI) or cabinet programming via cabinet programmer (article: 28001206)
- _ Wide operating window (1 output) to cover various LED module combinations
- _ In-field (re-)programming via NFC and u6Me2 possible after installation
- _ Enables energy metering and predictive maintenance
- _ High overvoltage protection: up to 10 kV asymmetric (protection class I and II)
- _ Integrated ESD protection

Typical applications

- _ Road & street, tunnel, residential, area and industrial lighting

Website

<http://www.tridonic.com/87501199>



Linear



High bay



Decorative



Downlights



Spotlights



Free-



Area



Floor | Wall



Street

Driver LCO 110W 200–1050mA 157V pD+ NF C SNC

essence D4i NFC outdoor series

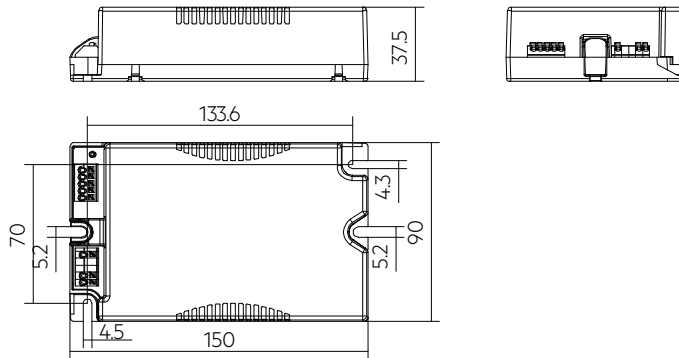
**Ordering data**

Type	Article number	Packaging, carton	Packaging, pallet	Weight per pc.
LCO 110/200-1050/157 pD+ NF C SNC	87501199	10 pc(s).	150 pc(s).	0.39 kg

Technical data

Rated supply voltage	220 – 240 V
AC voltage range	198 – 264 V
Mains frequency	50 / 60 Hz
Overvoltage protection	320 V AC, 48 h
Typ. rated current (at 230 V, 50 Hz, full load) ^{①②}	520 mA
Leakage current (at 230 V, 50 Hz, full load) ^{①②}	< 700 µA
Touch current (equipotential connected) ^③	600 µA
Max. input power	119 W
Output power range (P _{rated})	9.6 – 110 W
Efficiency (at 230 V, 50 Hz, full load)	92.5 %
λ over full operating range (max.) ^①	0.98
λ over full operating range (min.)	0.65C
Typ. power consumption on stand-by ^④	< 0.45 W
In-rush current (peak / duration)	45 A / 200 µs
THD (at 230 V, 50 Hz, full load) ^①	< 8 %
Starting time (AC mode)	< 700 ms
Turn off time (at 230 V, 50 Hz, full load)	< 30 ms
Output current tolerance ^{①⑤}	± 3 %
Max. output current peak (non-repetitive)	1,208 mA
Output LF current ripple (< 120 Hz)	± 5 %
Output P _{ST_LM} (at full load)	≤ 1
Output SVM (at full load)	≤ 0.4
Max. output voltage (U-OUT)	200 V
Dimming range ^⑥	10 – 100 %
Mains surge capability (between L - N) ^⑦	6 kV
Mains surge capability (between L/N - PE)	10 kV
Burst protection	4 kV
DALI burst capability	1 kV
Surge voltage at output side (against PE)	< 1 kV
Type of protection	IP20
Lifetime	up to 100,000 h
Guarantee (conditions at www.tridonic.com)	5 Year(s)
Dimensions L x W x H	150 x 90 x 37.5 mm

Approval marks**Standards**

EN 55015, EN 61000-3-2, EN 61000-3-3, EN 61000-4-4, EN 61000-4-5, EN 61347-1, EN 61347-2-13, EN 62384, EN 61547, EN 62386-101, EN 62386-102, EN 62386-150, EN 62386-207 (DALI-2)

Specific technical data

Type	Article number	Output current ^②	Min. output voltage	Max. output voltage	Max. output power	Typ. power consumption (at 230 V, 50 Hz, full load)	Typ. current consumption (at 230 V, 50 Hz, full load)	t _c point max.	Ambient temperature t _a
LCO 110/200-1050/157 pD+ NF C SNC	87501199	200 mA	48 V	157.0 V	31.4 W	35.2 W	161 mA	79 °C	-40 ... +65 °C
LCO 110/200-1050/157 pD+ NF C SNC	87501199	250 mA	48 V	157.0 V	39.3 W	43.4 W	195 mA	79 °C	-40 ... +65 °C
LCO 110/200-1050/157 pD+ NF C SNC	87501199	300 mA	48 V	157.0 V	47.1 W	51.7 W	231 mA	79 °C	-40 ... +65 °C
LCO 110/200-1050/157 pD+ NF C SNC	87501199	350 mA	48 V	157.0 V	55.0 W	59.8 W	266 mA	79 °C	-40 ... +65 °C
LCO 110/200-1050/157 pD+ NF C SNC	87501199	400 mA	48 V	157.0 V	62.8 W	68.1 W	301 mA	79 °C	-40 ... +65 °C
LCO 110/200-1050/157 pD+ NF C SNC	87501199	450 mA	48 V	157.0 V	70.7 W	76.3 W	336 mA	79 °C	-40 ... +65 °C
LCO 110/200-1050/157 pD+ NF C SNC	87501199	500 mA	48 V	157.0 V	78.5 W	84.4 W	372 mA	79 °C	-40 ... +60 °C
LCO 110/200-1050/157 pD+ NF C SNC	87501199	550 mA	48 V	157.0 V	86.4 W	92.6 W	407 mA	79 °C	-40 ... +60 °C
LCO 110/200-1050/157 pD+ NF C SNC	87501199	600 mA	48 V	157.0 V	94.2 W	100.9 W	443 mA	79 °C	-40 ... +60 °C
LCO 110/200-1050/157 pD+ NF C SNC	87501199	650 mA	48 V	157.0 V	102.1 W	109.1 W	478 mA	79 °C	-40 ... +60 °C
LCO 110/200-1050/157 pD+ NF C SNC	87501199	700 mA	48 V	157.0 V	109.9 W	117.3 W	514 mA	77 °C	-40 ... +55 °C
LCO 110/200-1050/157 pD+ NF C SNC	87501199	750 mA	48 V	146.6 V	110.0 W	117.5 W	515 mA	77 °C	-40 ... +55 °C
LCO 110/200-1050/157 pD+ NF C SNC	87501199	800 mA	48 V	137.5 V	110.0 W	117.6 W	515 mA	77 °C	-40 ... +55 °C
LCO 110/200-1050/157 pD+ NF C SNC	87501199	850 mA	48 V	129.4 V	110.0 W	117.7 W	516 mA	77 °C	-40 ... +55 °C
LCO 110/200-1050/157 pD+ NF C SNC	87501199	900 mA	48 V	122.2 V	110.0 W	117.8 W	516 mA	77 °C	-40 ... +55 °C
LCO 110/200-1050/157 pD+ NF C SNC	87501199	950 mA	48 V	115.8 V	110.0 W	118.0 W	517 mA	77 °C	-40 ... +55 °C
LCO 110/200-1050/157 pD+ NF C SNC	87501199	1,000 mA	48 V	110.0 V	110.0 W	118.3 W	519 mA	77 °C	-40 ... +55 °C
LCO 110/200-1050/157 pD+ NF C SNC	87501199	1,050 mA	48 V	104.8 V	110.0 W	118.6 W	520 mA	77 °C	-40 ... +55 °C

① Valid at 100 % dimming level.

② Depending on the selected output current.

③ Maximum of "perception and reaction" and "let go" values according to EN 60598-1.

④ Depending on the DALI traffic at the interface. DALI bus power supply deactivated. No-load on AUX power supply.

⑤ Output current is mean value.

⑥ Minimum 100 mA.

⑦ L-N acc. to EN 61000-4-5. 2 Ohm, 1,2/50 µs, 8/20 µs.

1. Standards

EN 55015
 EN 61000-3-2
 EN 61000-3-3
 EN 61000-4-4
 EN 61000-4-5
 EN 61347-1
 EN 61347-2-13
 EN 62384
 EN 61547
 EN 62386-101 (DALI-2)
 EN 62386-102 (DALI-2)
 EN 62386-150 (DALI-2)
 EN 62386-207 (DALI-2, including part 250, 251, 252, 253)

1.1 Glow wire test

according to EN 61347-1 with increased temperature of 850 °C passed.

1.2 Light modulation

according to IEC 1789 device fulfils "no observable effect level".

2. Thermal details and lifetime

2.1 Expected lifetime

Expected lifetime								
Type	Output current	ta	40 °C	45 °C	50 °C	55 °C	60 °C	65 °C
LCO 110/200-1050/157 pD+ NF C SNC	200 – 400 mA	tc	54 °C	59 °C	64 °C	69 °C	74 °C	79 °C
		Lifetime	> 100,000 h	> 100,000 h	> 100,000 h	> 100,000 h	75,000 h	50,000 h
	>400 – 700 mA	tc	59 °C	64 °C	69 °C	74 °C	79 °C	–
		Lifetime	> 100,000 h	> 100,000 h	> 100,000 h	75,000 h	50,000 h	–
	>700 – 1,050 mA	tc	62 °C	67 °C	72 °C	77 °C	–	–
		Lifetime	> 100,000 h	> 100,000 h	70,000 h	50,000 h	–	–

The LED driver is designed for a lifetime stated above under reference conditions and with a failure probability of less than 10 %.

The relation of tc to ta temperature depends also on the luminaire design.

If the measured tc temperature is approx. 5 K below tc max., ta temperature should be checked and eventually critical components (e.g. ELCAP) measured. Detailed information on request.

3. Installation / wiring

3.1 Circuit diagram

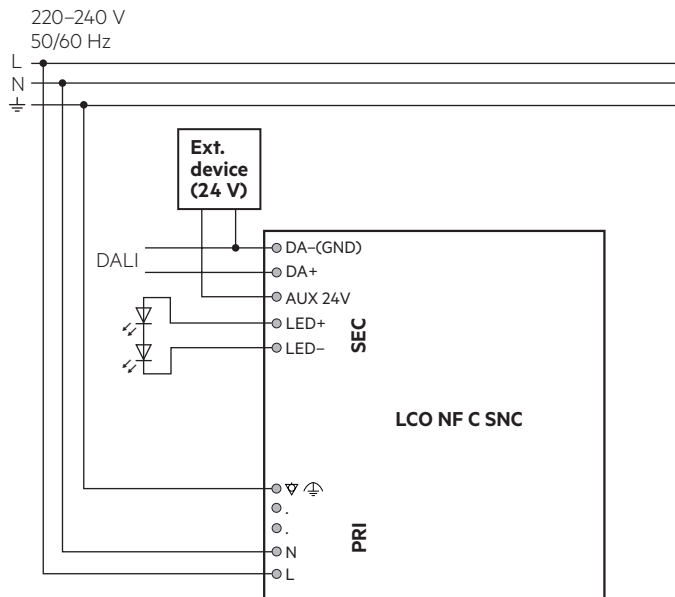

3.2 Wiring type and cross section

For wiring use solid or stranded wire from 0.2 – 1.5 mm². Strip 8.5 – 9.5 mm of insulation from the cables to ensure perfect operation of terminals.

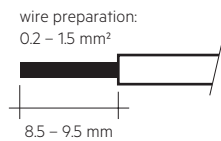

3.3 Wiring guidelines

- Run the secondary lines separately from the mains connections and lines to achieve good EMC performance.
- The max. secondary cable length (AUX, LED) is 2 m (4 m circuit).
- For good EMC performance, keep the LED wiring as short as possible.
- Secondary switching is not permitted.
- The LED driver has no inverse-polarity protection on the secondary side. Wrong polarity can damage LED modules with no inverse-polarity protection.
- Wrong wiring of the LED driver can lead to malfunction or irreparable damage.
- To avoid damage of the Driver, the wiring must be protected against short circuits to earth (sharp edged metal parts, metal cable clips, louver, etc.).

3.4 Hot plug-in

Hot plug-in is not supported due to residual output voltage of > 0 V. When connecting an LED load, restart the device to activate the LED output. This can be done via mains reset or via interface (DALI).

3.5 Earth connection

The earth connection is conducted as function earth (FE). There is no earth connection required for the functionality of the LED driver. Earth connection is recommended to improve following behaviour:

- Electromagnetic interferences (EMI)
- LED glowing at standby
- Transmission of mains transients to the LED output

4. Electrical values

4.1 Operating window

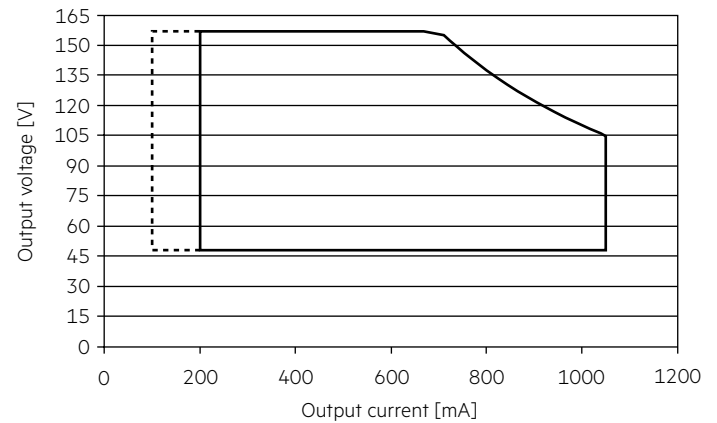

- Operating window 100 %
- - - - - Operating window dimmed (minimum 100 mA)

Make sure that the LED driver is operated within the given window under all operating conditions. Special attention needs to be paid at dimming as the forward voltage of the connected LED modules varies with the dimming level, due to the implemented amplitude dimming technology. Coming below the specified minimum output voltage of the LED driver may cause the device to shut-down.

4.2 Efficiency vs load

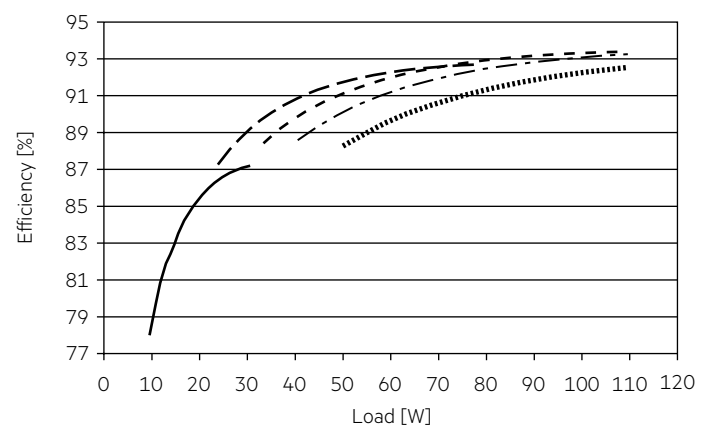

DALI bus power supply deactivated. No-load on AUX power supply.

- 200 mA
- - - - - 500 mA
- - - - - 700 mA
- - - - - 850 mA
- 1050 mA

4.3 Power factor vs load

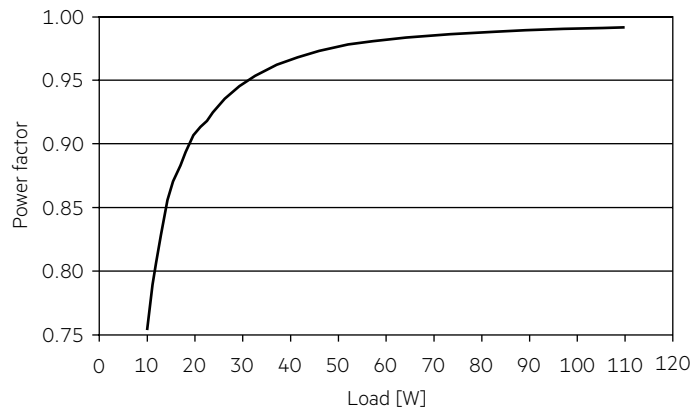

4.4 THD vs load

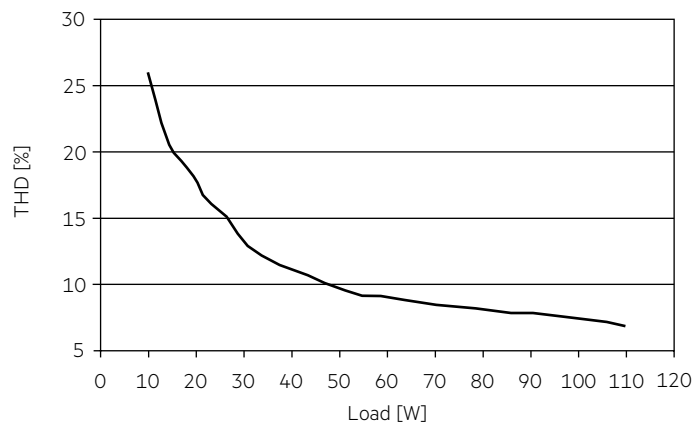

4.8 Maximum loading of automatic circuit breakers in relation to inrush current

Automatic circuit breaker type	C10	C13	C16	C20	B10	B13	B16	B20	Inrush current	
									I_{max}	time
LCO 110/200-1050/157 pD+ NF C SNC	9	12	14	18	7	9	11	14	45 A	200 μ s

These are max. values calculated out of inrush current! Please consider not to exceed the maximum rated continuous current of the circuit breaker. Calculation uses typical values from ABB series S200 as a reference. Actual values may differ due to used circuit breaker types and installation environment.

4.9 Harmonic distortion in the mains supply (at 230 V / 50 Hz and full load) in %

	THD	3.	5.	7.	9.	11.
LCO 110/200-1050/157 pD+ NF C SNC	< 7	< 7	< 5	< 5	< 5	< 3

5. Software / Programming / Interfaces

5.1 Software / programming

With appropriate software and interface different functions can be activated and various parameters can be configured in the LED driver. The Driver supports the following software and interfaces:

Software / hardware for configuration:

- companionSUITE (deviceGENERATOR, deviceCONFIGURATOR, deviceANALYSER)
- masterCONFIGURATOR

Interfaces for data transfer:

- NFC
- Control input DALI
- U6Me2

5.2 Nearfield communication (NFC)

The NFC Interface allows wireless communication with the LED driver. This interface offers the option to write configuration and to read configuration, errors and events with the companionSUITE. A correct communication between the LED driver and the NFC antenna can only be guaranteed if the antenna is placed directly on the Driver. Any material placed between the LED driver and the NFC antenna can cause a deterioration of the communication quality. After programming the device via NFC power up the device one time for one second till the deviceANALYSER can read out the parameters. We recommend the use of following NFC antenna:
www.tridonic.com/nfc-readers

NFC is complied with ISO/IEC 15963 standard.

5.3 Control input DALI

The control signal is not SELV. The control cable has to be installed in accordance to the requirements of low voltage installations.

Digital control with:

- DALI signal: 16 bit

Dimming is realized by amplitude dimming.

5.4 U6Me2

Settings of chronoSTEP function could be done via switching mains commands. For detailed description for timings and intervals see product manual.

Key features:

- Auto-dimming with 1 sequence
- Every sequence can hold 8 parameter pairs
- Separate dim-level for each time parameter
- Various commands + parameter for extensions

6. Functions

 companionSUITE:

DALI-USB, NFC

The companionSUITE with deviceGENERATOR, deviceCONFIGURATOR and deviceANALYSER is available via our WEB page:

<https://www.tridonic.com/com/en/products/companionsuite.asp>

 masterCONFIGURATOR:

DALI-USB

The masterCONFIGURATOR is available via our WEB page:

<https://www.tridonic.com/com/en/software-masterconfigurator.asp>

 4service NFC app:

Smartphone with NFC

4service NFC app is available via the corresponding app store.

Additional information: https://www.tridonic.com/com/en/download/brochures/Leaflet_companionSUITE_EN.pdf

Icon	Function	NFC	DALI-2	U6Me2
	OEM Identification	 -	 	-
	OEM GTIN	 -	 	-
	Luminaire data	 -	 	-
	LED current	 	 	-
	Factory reset	 -	 	-
	Device operating mode	 	 	
	chronoSTEP	 	 	
	Constant light output (CLO)	 -	 	-
	Intelligent temperature guard (ITG)	 -	 	-
	DALI default parameters	 -	 	-
	Scenes and groups	 -	 	-
	Addressing	 	 	-
	pDALI integrated DALI bus voltage	 	 	-
	deviceKEY	 -	 	-
	Power-up fading	 -	 	-
	Intelligent voltage guard (IVG)	 -	 	-
	Dimming curve	 -	 	-
	Energy reports	 	 	-
	Diagnostic and monitoring	 	 	-
	Last Gasp	 	 -	-

6.1 OEM Identification



The OEM (Original Equipment Manufacturer) can set his own identification number.

DALI Part 251: Memory bank 1 extension.

6.2 OEM GTIN



The Original Equipment Manufacturer (OEM) can set his own Global Trade Item Number (GTIN).

DALI Part 251: Memory bank 1 extension.

6.3 Luminaire data



This function provides the asset management with accurate data about the luminaire.

DALI Part 251: Memory bank 1 extension.

6.4 LED current



The LED output current must be adapted to the connected LED module. The value is limited by the current range of the respective device.

6.5 Device operating mode



A Tridonic Driver supports several control signals.

These control signals are automatically detected and the mode is adapted.

If only one special device mode is required, this mode can be selected.

“Automatic detection” is the default setting.

6.6 Factory reset



This device supports the function to reset all parameters back to factory defaults.

6.7 chronoSTEP (Virtual Midnight)



In the outdoor lighting and street lighting sector it often makes sense to dim the lighting level during night hours in order to save energy.

The chronoSTEP function is a tool that makes this easy to do.

The device automatically measures the switch-on and switch-off times of the lighting installation over the past three days.

The switch-on and switch-off times are typically the times at which the sun sets and rises. The midpoint of these two reference points is the time referred to as Virtual Midnight. The overall time interval between switch-on and switch-off points is called On Time.

Notice

When calculating the On Time, only values between 4 and 24 hours are counted. Values less than 4 hours could indicate a power failure and are therefore not saved. For settings longer than 24 hours, 24 hours is saved as the maximum possible value.

6.8 Integrated DALI bus power supply



This function complies to DiiA specification DALI Part 250 - Integrated bus power supply.

The output power of the integrated DALI Bus Power Supply (pDALI) has an output current of 50 mA (max. 62.5 mA).

It is activated by factory default.

Sensors and also external drivers could be directly connected to this power supply. The DALI power supply could be deactivated via software.



Power supplies can be combined up to 250 mA max in total.

This maximum must not exceed. The polarity has to be considered.

If the DALI power supply is activated, the driver must not be integrated into an existing, already with 250 mA powered DALI network.

6.9 AUX power supply



An auxiliary (AUX) supply provides 24 V DC to power e.g. a controller, an occupancy sensor, a photo sensor or other device. It eliminates the need of an AC/DC supply and the associated need of surge suppression and an EMI filter in such devices.

AUX supply specification:

Average power of 3 W.

Average output voltage of 24 V \pm 10 %

Maximum voltage does not exceed 30 V under any load condition including open circuit.

Start-up time: 90 % of the nominal specified voltage level within 600 ms after applying mains power.

Start-up: After power-on, the load must limit the current consumption at the AUX terminals to at most 160 mA until the specified voltage is reached.

6.10 Intelligent Temperature Guard (ITG)



The intelligent temperature guard protects the LED driver from thermal overheating by reducing the output power or switching off in case of operation above the thermal limits of the luminaire or ballast. Depending on the luminaire design, the ITG operates at about 5 to 10 °C above t_c temperature.

If temperature threshold values are exceeded, the LED output current is limited. These limits can be adjusted using the programming software. Even the current ITG temperature in the device can be read out. With this function, the sensitivity of the temperature control can be adjusted.

6.11 Power-up fading



The power-up function offers the opportunity to modify the on behavior. The time for fading on can be adjusted in a range of 0.2 to 16 seconds. According to this value, the device dims either from 0 % up to the power-on level. By factory default no fading time is set (= 0 seconds).

6.12 deviceKEY



With this function, individual device functions can be protected from unauthorized changes by a password.

6.13 DALI default parameters



In order for all luminaires to react the same for each operation (switching, dimming, scene recall ...), these values must be set the same. These DALI standard parameters are supported by every DALI-2 device.

6.14 Scenes and groups



Each device can be a member of up to 16 groups. Also, 16 different scene values can be stored in each device.

6.15 Constant Light Output (CLO)



With this function the light output of the LED module can be kept equal over the lifetime.

The light output of an LED module reduces over the course of its lifetime. The Constant Light Output (CLO) function compensates for this natural decline by constantly increasing the output current of the LED driver throughout its lifetime.

CLO shall be achieved by limitation of the LED current at the commissioning of the LED driver and providing a linear interpolation of the current over the time, depending on the data points given by the user.

6.16 Energy reporting



This function provides the information related to energy reporting accessible through memory banks in this driver.

Several functions and values could be read out to gain access in Content management systems.

Report and values for Active power, Active Energy and many more can be read out.

6.17 Diagnostics & Maintenance



This function provides the information related to diagnostics and maintenance information accessible through memory banks.

Several functions and values could be read out to gain access in Content management systems.

Report and values for failure behaviour, driver conditions and malfunctions trigger points can be read out.

6.18 Last Gasp



This function enables the connected application controller to identify a mains power supply loss situation and perform "last second" operations before shutdown, e.g.:

- Send out a message (e.g. wireless to host system)
- Store data

If mains shut down the driver supports:

- Signaling the mains power supply outage by pulling the DALI-2 internally bus power supply signal to low
- Providing the required energy budget via 24V AUX power supply (≥ 300 mJ)

Per default the function is deactivated and can be activated via DALI-2 or NFC over the companionSUITE.

This function is only available in AC mains operation.

7. Protective features

7.1 Overtemperature protection

The LED driver is protected against temporary thermal overheating. If the temperature limit is exceeded the output current of the LED module(s) is reduced. The temperature protection is activated above $t_{c\ max}$. The activation temperature differs depending on the LED load. On DC operation this function is deactivated to fulfill emergency requirements.

7.2 Short-circuit behaviour

In case of a short-circuit at the LED output the LED output is switched off. After restart of the LED driver the output will be activated again. The restart can either be done via mains reset or via interface (DALI).

7.3 No-load operation

The LED driver will not be damaged in no-load operation. The output will be deactivated and is therefore free of voltage. If a LED load is connected, the device has to be restarted before the output will be activated again.

7.4 Overload protection

If the maximum load is exceeded by a defined internal limit, the LED driver turns off the LED output. After restart of the LED driver the output will be activated again. The restart can either be done via mains reset or via interface (DALI).

7.5 IVG+ – Intelligent Voltage Guard Plus



In some cases mains voltage is not stabilized and has some voltage peaks which are lower or higher than the nominal voltage range. Between 192 V and 80 V input voltage, the LED driver operates in under-voltage mode and dims the secondary side linearly down to 10 %. Below 80 V input voltage, the LED driver shuts down, restarts at 90 V (without a reset) and dims linearly up back to 100 %. Above 280 V input voltage, the LED driver shuts down. If input voltage drops below 270 V, the LED driver restarts (without a reset). Under no circumstances will the output current drop below the minimum supported LED current. For example, even in under-voltage conditions, the output current will not fall below this minimum limit. If a decrease in mains voltage attempts to reduce the output current, it will be prevented from dropping below the minimum supported LED current.

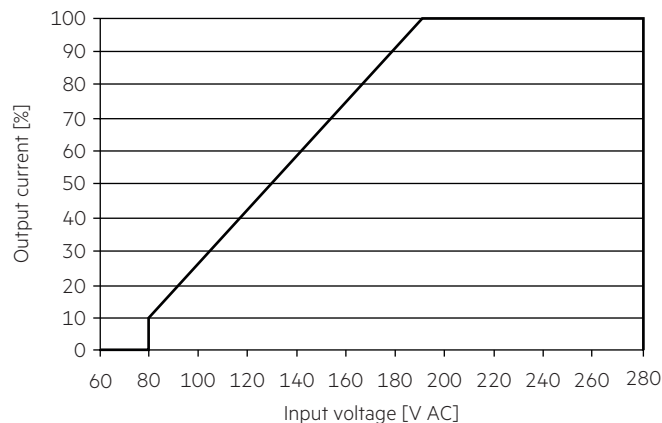

7.6 Insulation between terminals

Insulation	Mains	LED	pD+	FE
Mains	–	double	double	double
LED	double	–	basic	double
pD+	double	basic	–	double
FE	double	double	double	–

basic ... represents basic insulation.

double ... represents double or reinforced insulation.

7.7 OEM key

OEM key memory banks could be protected from unauthorized access with special master key.

7.8 ESD protection

The potential risk of electrostatic discharge (ESD) during certain weather conditions (like dry air and wind) and using the drivers in an installation on non-conductive poles is avoided.

8. Miscellaneous

8.1 Insulation and electric strength testing of luminaires

Electronic devices can be damaged by high voltage. This has to be considered during the routine testing of the luminaires in production.

According to IEC 60598-1 Annex Q (informative only!) or ENEC 303-Annex A, each luminaire should be submitted to an insulation test with 550 V_{DC} for 1 second. This test voltage should be connected between the interconnected phase and neutral terminals and the earth terminal. The insulation resistance must be at least 2 MΩ.

As an alternative, IEC 60598-1 Annex Q describes a test of the electrical strength with 1550 V_{AC} (or 1.414 x 1550 V_{DC}). To avoid damage to the electronic devices this test must not be conducted.

The equipotential terminal is used to connect the heat sink and the LED driver to reduce transients.

8.2 Conditions of storage and use

Humidity: 5% up to max. 95%,
not condensed

Storage temperature: -40 °C up to max. +80 °C

The devices have to be acclimatised to the specified temperature range (ta) before they can be operated.

The LED driver is declared as inbuilt LED controlgear, meaning it is intended to be used within a luminaire enclosure.

If the product is used outside a luminaire, the installation must provide suitable protection for people and environment (e.g. in illuminated ceilings).

8.3 Maximum number of switching cycles

All LED driver are tested with 50,000 switching cycles.
The actually achieved number of switching cycles is significantly higher.

8.4 Additional information

Additional technical information at www.tridonic.com → Technical Data

Lifetime declarations are informative and represent no warranty claim.
No warranty if device was opened.